

Conventional Detector Base Sounder

DBS - 4

Overview

- 4 Tone sounder
- High sound output, low current consumption
- High reliability and stable performance
- Volume control
- Lid accessory available to enable vertical installation
- Designed and approved to EN54-3
- CE marked
- Unobtrusive low profile



166c

Description

Our conventional audible visual devices operate over a wide input voltage range of 9 to 33VDC and are optimised for use on 12V and 24V systems, making them suitable for use in both fire and security applications.

The conventional range of detector base sounders are available in standard 4 tone version in a white colour with locally controllable output levels to enable the sound intensity to be adjusted to suit the application.

The detector base sounders are suitable for fire detectors with 60mm mounting centres. The sounders can also be fitted with a red or white lid in place of a fire detector, enabling them to be positioned vertically on the wall. This arrangement provides an extremely low profile unit which is unobtrusive and protrudes only 35mm from the wall.

The distinctive low profile shape is acoustically very efficient, producing an omni-directional high sound output at low current levels. Rugged construction with solid state electronics also provides high reliability and stable performance.

All wall mount sounder products ensure full compliance as they are designed and approved to EN54-3 and also CPD (Construction Products Directive) approved

Convantional Detector Base Sounder DBS - 4

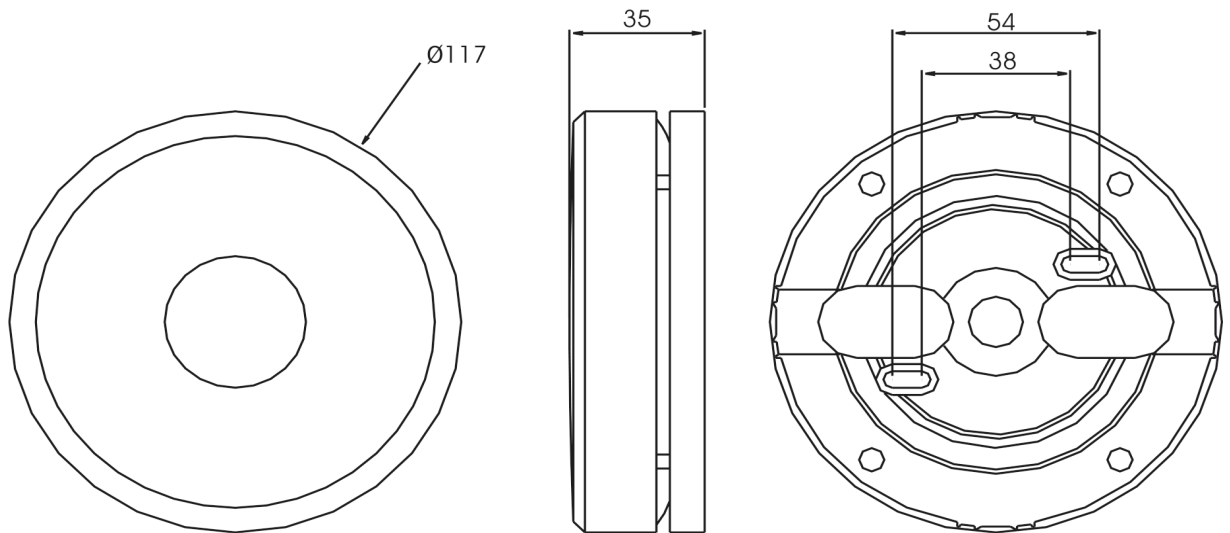

Electrical Specifications - Standard Product (DBS - 4)

Operating Voltage Range	9 to 33VDC (Approved to 10-14V and 21-27V)
Sound Output	up to 92db(A) @1m

Environmental Specifications

Operating Temperature Voltage	-25°C to 70°C (with sealing kit)
Relative Humidity	Up to 96% @50°C
Ingress Protection	IP24D

Mechanical Information

Depth	35mm
Diameter	117mm
Weight	200g
Colour	White
Material	PC/ABS

Product Range

Compatible Bases	
Other Devices in range	Please refer to other ADEVA Datasheets
Other Colours in range	

Note * When installed in a B501AP base

! Do not install detectors in locations where normal ambient temperature exceeds 50°C

ADEVA LTD. Fire Alarm Systems

Guldeste Sok. No:24 Yakacik
Kartal / Istanbul / Turkey

Tel: +90 (0)216 5982800 Fax: +90 (0)216 5982899
Email: info@adevafire.com www.adevafire.com

Copyright © 2009 ADEVA. All rights reserved.

All technical data is correct at time of publication and is subject to change without notice. All trademarks acknowledged. Installation information: in order to ensure full functionality, refer to the installation instructions as supplied.