

## Intelligent Carbon Monoxide Detector FCGD319CO

### Overview

- Multi Level adjustable analogue CO sensing technology
- Up to 100 devices per loop
- Low loop current and low stand by and alarm current
- Driven by ADEVA Protocol
- Available with or without single pole short circuit isolation with status control through the ADEVA Protocol
- Power, ready, fault and Alarm LEDs with red, green and amber colours
- New mechanical platform with revolutionary chamber offering improved false alarm immunity
- Improved resilience to false alarms through dust
- Removed risk of false alarms through insects
- Manuel Test Button
- Pure white colour to compliment modern buildings
- New Base design to compliment the detector
- Internal buzzer



### Description

The Carbon Monoxide Addressable detector use the most modern technological sensors available today. The detector can be tested against small amount of CO into the detector as its sensors are designed to even detect with in seconds of the smoke caused within the functioning area of the sensor thus detecting an alarm.

When the hazardous amount of CO smoke is detected, the FCGD319CO detectors alerts the residents by sound and flashing an audible or visual alarm and also equipped with four illuminated LED's as indicators. With 24/7 central station monitoring, residents are guaranteed protection whether they are away from home, sleeping or unaware of any CO leakages, suffering residence.

The FCGD319CO are designed for system operation. The FCGD319CO coloured wiring codes make it easy it easier to locate a fault in gas alarm control panel and also address must be programmed only by authorized programmers. With a low current draw. This detector enable more devices to be connected to the panel thus limiting the need to purchase of more fire alarm control panels or other power supplies. As 12/30 VDC detector, FCGD319CO will operate on most industry security and gas alarm control panels.

Adjustable CO level initiating capability expand usage for more application and also give the flexibility for diffrent programing for CO exhaust senaries.

Adressable CO alarm system is able to control all HVAC systems base on zone identification by loop driven output modules. It helps to designer to make more flexible CO alarm system designs for even very large systems and helps to installer to make less cabling. It also helps to user for less CO system investment and to localize alarming detector as point by 40 character text address message on the panel.

## Intelligent Carbon Monoxide Detector FCGD319CO

### Architect/Engineers Specifications

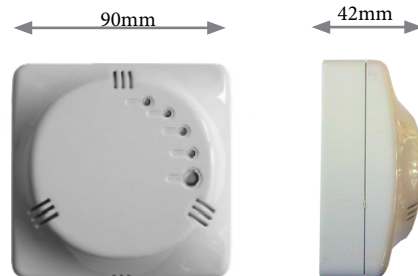

### Electrical Specifications

Loop Operating Voltage	: 12-30 VDC
Loop Operating Current	: <600 $\mu$ A @ 24 VDC
Max. Loop Alarm Current	: <7 mA @ 24 VDC
DC Operating Voltage	: 12-30 VDC
DC Operating Current	: <50mA @ 24VDC

### Physical Specifications

Operating Humidity Range	: 10% - 93%
Operating Temperature	: -10°C - +50°C
Gas Volume Ratio	: 50ppm
Relay Output Ratio	: 200mA @24VDC

### Mechanical Specifications

Dimension	: 90x90x38mm
Weight	: 110gr

### Installation Specifications

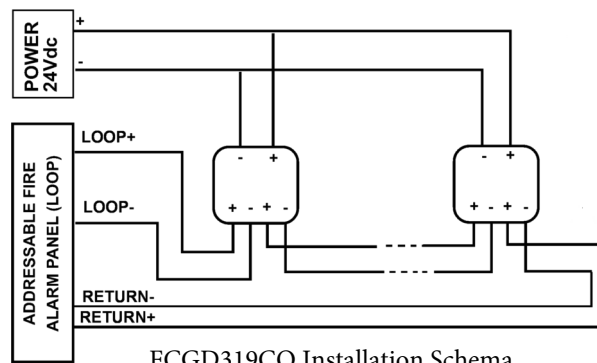

ADEVA Gas Alarm Systems

Guldeste Sok. No:24 Yakacik  
Kartal / Istanbul / Turkey

Tel: +90 (0)216 5982800 Fax: +90 (0)216 5982899  
e-mail: info@adevafire.com www.adevafire.com

Copyright © 2009 ADEVA. All rights reserved.

All technical data is correct at time of publication and is subject to change without notice. All trademarks acknowledged. Installation information: in order to ensure full functionality, refer to the installation instructions as supplied. Spelling errors excepted.