

# 100V Power Amplifier FCVA12

## Overview

- 100 V Constant voltage output
- 120 Watt output power
- Class A/B Amplifier Technology
- XLR Signal Linkthrough
- Advanced Protection circuit
- High pass filter switch & signal limiter
- Ground lift switch
- 24 V Emergency power operation
- 19" Mounting device (2 HE)



## Description

The FCVA12 is the 120 Watt version of the FCVA series single channel power amplifiers. It features an output power of 120 Watt with different connections for use in 100 V and 70 V constant voltage public address systems or 4 Ohm low impedance applications.

They are designed as no-nonsense amplifiers with only the necessary controls and connections, which provides great simplicity in use and installation. They are designed as Class-AB Amplifiers with a multi-tapping output transformer.

A built-in multipurpose protection circuit protects against DC malfunction, Short circuit, overheating, overload and limits the signal when necessary.

The input connections are performed using balanced XLR connectors and link XLR output connectors are provided for linkthrough to other amplifiers.

A high-pass filter switch (400 Hz) and a Gain adjustment potentiometer whereby the input sensitivity can be adjusted within a range from -12 dB to 0 dB are provided. A ground-lift switch allows the elimination of humming sound produced by ground loops.

A 24 Volts alternative power connection performed using a 2-pin terminal block is provided to power the amplifier on emergency power once the mains power is shut down.

The output connections are performed using reliable terminal block connectors and this all is housed into a solid constructed, double rack space (2 HE) 19" rack mounting housing.

SYSTEM SPECIFICATIONS	
RMS Power	2 x 240 Watt
Frequency response	50 Hz - 22 kHz
Signal to noise ratio	> 100 dB
THD+N by 1 kHz (1/2 Rated Power)	< 0.3%
Crosstalk	< 80 dB
Technology	Class-D
Power supply	Switching mode
Power supply range	230 ~ 240 V AC / 50 Hz
Input Sensitivity	-0.5 dB ~ 10.5 dB
Input Impedance	10 k Ohm balanced
Output Voltage / Impedance	100 V (42 Ohm)
Common mode rejection ratio	70 dB
Protection	DC Short-circuit Over heating Over load Signal limiting
Cooling system	Temperature controlled FAN
Operating temperature	0° ~ 40° at 95% Humidity
Connectors	Input      Female XLR with Male Linkthrough Output      4-Pin Terminal block (5.08 mm pitch)

PRODUCT FEATURES	
Dimensions (Width x Height x Depth)	482 x 88 x 420 mm
Weight net	7.2 Kg
Mounting	19"
Unit height	2 HE
Construction	Steel
Colour	Black
SHIPPING & ORDERING	
Packaging	Carton box
Shipping weight and volume	10.5 Kg - 0.046 Cbm
Accessories included	2 x 4-Pin Terminal block Output con.
Optional accessories	CPE100 Rack mount handles
*ADEVA reserves the right to change specifications without notice: this is part of our policy to continually improve our products	

# 100V Power Amplifier FCVA12

## Architect's and Engineers' Specifications

The Amplifier shall be a constant voltage 100 Volt type with an output power of 120 Watt. The construction shall be made using Class-AB Amplifier technology with an 100 V output transformer. It shall contain integrated circuitry to protect against short-circuits or mismatched loads and over-heating. The operating temperature shall be continuously monitored and controlled using a dual speed fan driver. Additionally, the load shall be protected against DC faults and a clip limiter shall automatically reduce the input gain at onset of distortion.

The front panel shall contain an AC power switch accompanied by a blue power indicator LED and operation indicator LED's. Two green signal LED's indicating the presence of an input signal and it's level exceeding the -20 dB level, a yellow clip LED indicating the operation at maximum level and a red protection LED indicating any fault detected shall be provided.

All connections shall be made on the rear panel of the unit. The signal input connection shall be balanced and performed using a female XLR connector with male XLR connector allowing signal link through to other amplifiers. A gain control potentiometer shall be provided to adjust the input sensitivity within a range of -12 dB to 0 dB, and a switch shall allow the enabling / disabling of a high-pass filter with a roll off frequency of 400 Hz.

The output connections shall be performed using a 4-pin Terminal block connector with three different power taps for use with 100 Volt, 70 Volt constant voltage and 4 Ohm low impedance applications.

The power supply shall be a conventional type operating on a 230~240 V AC / 50~60 Hz mains network, which is adaptable to 110~115 V AC / 50~60 Hz operation by making some minor internal adjustments on the power transformer connections. Additionally, an emergency power inlet shall be provided to keep the system running on 24 Volt emergency power when the mains power is shut down.

It shall be equipped with a removable power cord having a standard shuko (CEE 7/7) AC plug. The connector on the amplifier chassis shall be a fused IEC C14 type and the emergency power inlet shall be performed using a 2-pin terminal block connector .

The amplifier chassis shall be a two rackspace steel constructed 19" housing. Depth from mounting surface to rear supports shall be 330 mm and the weight shall not exceed 10.5 Kg.

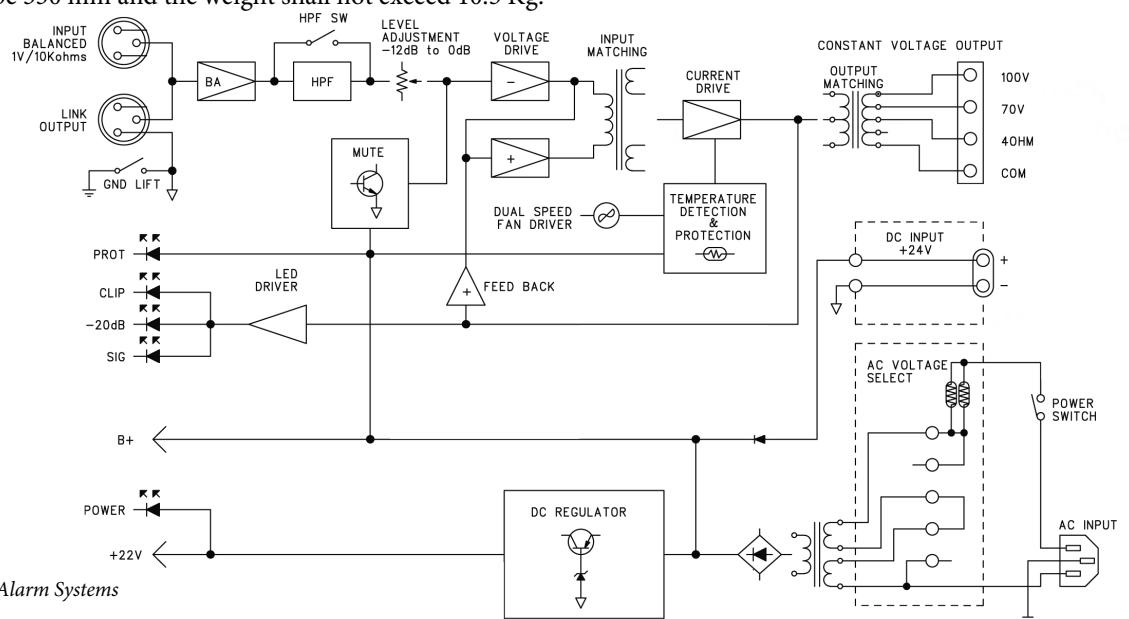

ADEVA LTD. Fire Alarm Systems

Guldeste Sok. No:24 Yakacik  
Kartal / Istanbul / Turkey

Tel: +90 (0)216 5982800 Fax: +90 (0)216 5982899  
Email: info@adevafire.com www.adevafire.com

Copyright © 2009 ADEVA. All rights reserved.

All technical data is correct at time of publication and is subject to change without notice. All trademarks acknowledged. Installation information: in order to ensure full functionality, refer to the installation instructions as supplied.