

Quad Channel 100V Power Amplifier

FCVA412

Overview

- 4 x 100 Volt outputs
- 120 Watt output power
- 100V, 70V and 4 Ohm outputs
- Class-D Amplifier Technology
- XLR Signal Linkthrough
- Advanced Protection circuit
- Temperature controlled fan
- High pass filter switch & signal limiter
- 19" Mounting device (2 HE)



Description

The FCVA Series are professional 100V Multi-Channel Power Amplifiers, containing various models with different channels and different output power configuration.

The FCVA412 is the four channel version with an output power of 120 Watt at each channel. This offers a flexible solution for Multi-Zone audio distribution systems with four or more independent zones.

They are designed as no-nonsense amplifiers with only the necessary controls and connections, which provides great simplicity in use and installation. A high efficiency and reliability of the devices is achieved by using switching power supplies in combination with Class-D Amplifier technology. A temperature controlled FAN constantly keeps all parts within the right operating range, while avoiding excessive buzz. A built-in multipurpose protection circuit protects against DC malfunction, Short circuit, overheating, overload and limits the signal when necessary.

The input connections are performed using balanced XLR connectors and link XLR output connectors are provided for linkthrough to other amplifiers.

Every output channel contains different power taps to be used in 100 Volt, 70 Volt and even 4 Ohm low impedance applications.

Besides, a high-pass filter switch (400 Hz) and a Gain adjustment potentiometer are provided for each channel.

The output connections are performed using reliable terminal block connectors and this all is housed into a solid constructed, double rack space (2 HE) 19" rack mounting housing.

SYSTEM SPECIFICATIONS	
RMS Power	4 x 120 Watt
Frequency response	50 Hz - 22 kHz
Signal to noise ratio	> 100 dB
THD+N by 1 kHz (1/2 Rated Power)	< 0.3%
Crosstalk	< 80 dB
Technology	Class-D
Power supply	Switching mode
Power supply range	230 ~ 240 V AC / 50 Hz
Input Sensitivity	-0.5 dB ~ 10.5 dB
Input Impedance	10 k Ohm balanced
Output Voltage / Impedance	100 V (42 Ohm)
Common mode rejection ratio	70 dB
Protection	DC Short-circuit Over heating Over load Signal limiting
Cooling system	Temperature controlled FAN
Operating temperature	0° ~ 40° at 95% Humidity
Connectors	Input Female XLR with Male Linkthrough Output 4-Pin Terminal block (5.08 mm pitch)

PRODUCT FEATURES	
Dimensions (Width x Height x Depth)	482 x 88 x 420 mm
Weight net	7.2 Kg
Mounting	19"
Unit height	2 HE
Construction	Steel
Colour	Black
SHIPPING & ORDERING	
Packaging	Carton box
Shipping weight and volume	10.5 Kg - 0.046 Cbm
Accessories included	2 x 4-Pin Terminal block Output con.
Optional accessories	CPE100 Rack mount handles
*ADEVA reserves the right to change specifications without notice: this is part of our policy to continually improve our products	

Quad Channel 100V Power Amplifier FCVA412

Architect's and Engineers' Specifications

The Amplifier shall be a constant voltage 100 Volt type, containing four independent controllable amplifier channels with an output power of 4 x 120 Watt. The amplifier shall be constructed using Class-D Amplifier technology and powered by a switching power supply. Each channel shall have integrated circuitry to protect against short-circuits or mismatched loads and over-heating. The operating temperature for each channel shall be continuously monitored and a speed-controlled fan will keep it within the operating range while minimising the acoustic noise. Additionally, the load shall be protected against DC faults and a clip limiter shall automatically reduce the input gain at onset of distortion.

The front panel shall contain an AC power switch accompanied by a blue power indicator LED and channel operation indicator LED's. Two green signal LED's indicating the presence of an input signal and it's level exceeding the -20 dB level, a clip LED indicating the channel operation at maximum level and a protection LED indicating any fault detected shall be provided for each channel.

All connections shall be made on the rear panel of the unit. The signal input connections shall be balanced and performed using female XLR connectors with male XLR connectors allowing signal link through to other channels or amplifiers. A gain control potentiometer shall be provided to adjust the input sensitivity within a range of -0.5 dB to 10.5 dB, and a switch shall allow the enabling / disabling of a high-pass filter with a roll off frequency of 400 Hz.

The output connections shall be performed using a 4-pin Terminal block connector with three different power taps for use with 100 Volt and 70 Volt constant voltage and 4 Ohm low impedance applications.

The amplifier shall operate on a 230~240 V AC / 50 Hz mains network and shall be equipped with a removable power cord having a standard shuko (CEE 7/7) AC plug. The connector on the amplifier chassis shall be a fused IEC C14 type.

The amplifier chassis shall be a two rackspace steel constructed 19" housing. Depth from mounting surface to rear supports shall be 420mm and the weight shall not exceed 14.8 Kg.

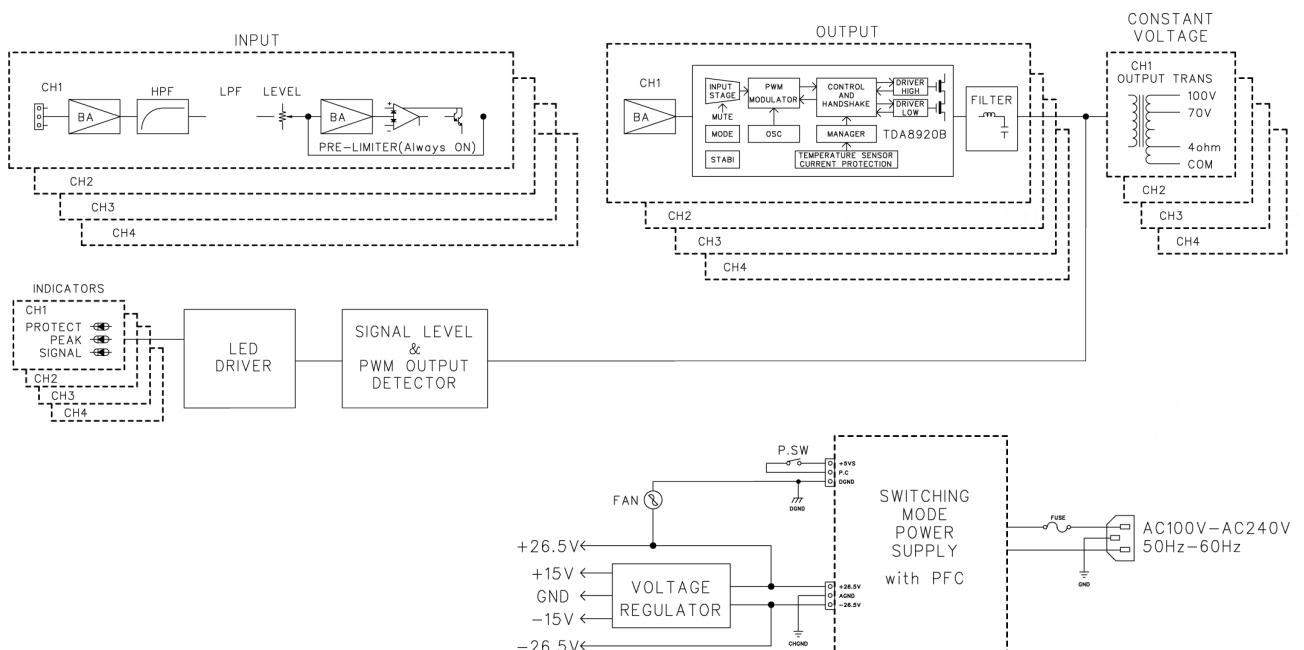

ADEVA LTD. Fire Alarm Systems

Guldeste Sok. No:24 Yakacik
Kartal / Istanbul / Turkey

Tel: +90 (0)216 5982800 Fax: +90 (0)216 5982899
Email: info@adevafire.com www.adevafire.com

Copyright © 2009 ADEVA. All rights reserved.

All technical data is correct at time of publication and is subject to change without notice. All trademarks acknowledged. Installation information: in order to ensure full functionality, refer to the installation instructions as supplied.